

TYPE	RANGE	PRE-TRAVEL
'X'	0.5	0.01/0.02
'Y'	0.5	0.01/0.02
'Z'	0.5	0.01/0.02
'Q'	0.5	0.01/0.02

NOTES:-

- ALL TIPS ARE AVAILABLE IN SYNTHETIC RUBY, SILICON NITRIDE & TUNGSTEN CARBIDE MATERIALS.
- SEE RECOMMENDED MOUNTING REQUIREMENTS:
 - VIEW 'A' - CLEARANCE TO ALLOW FULL MOVEMENT OF THE MEASURING ARM.
 - VIEW 'B' - MINIMUM RECOMMENDED DISTANCE IN CLOSE PROXIMITY.

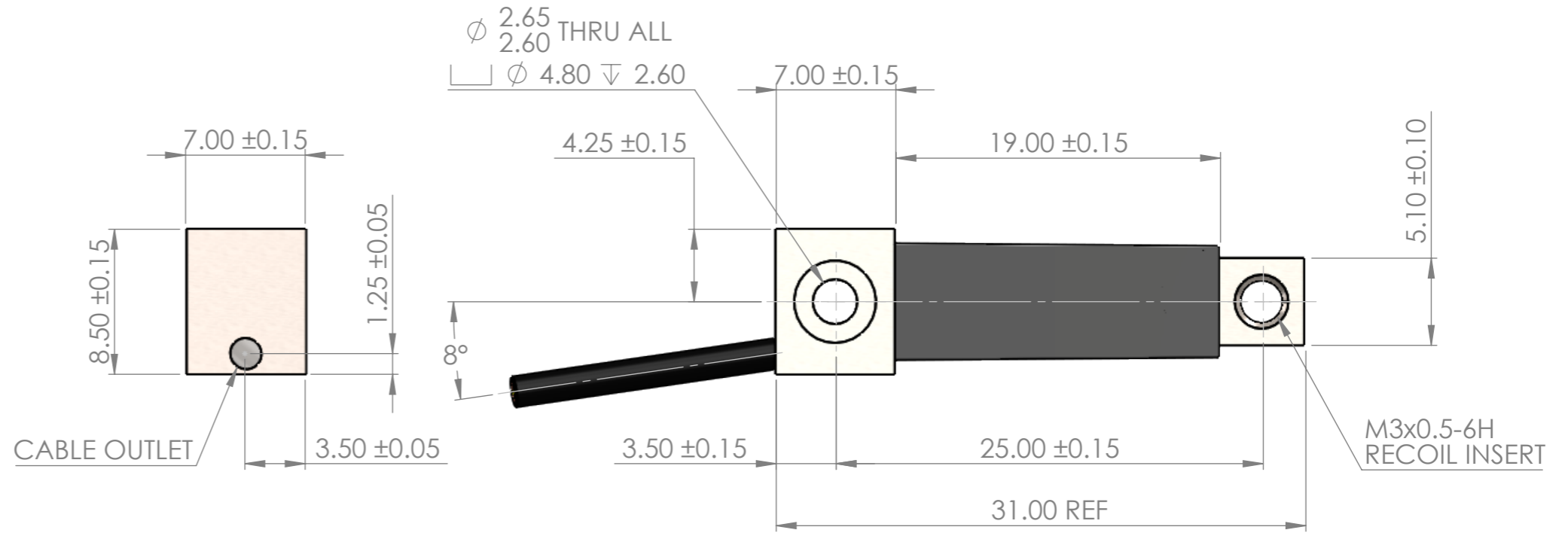

MOUNTING REQUIREMENTS

TYPE 'X' - M3 SELF LOCKING INSERT VERSION

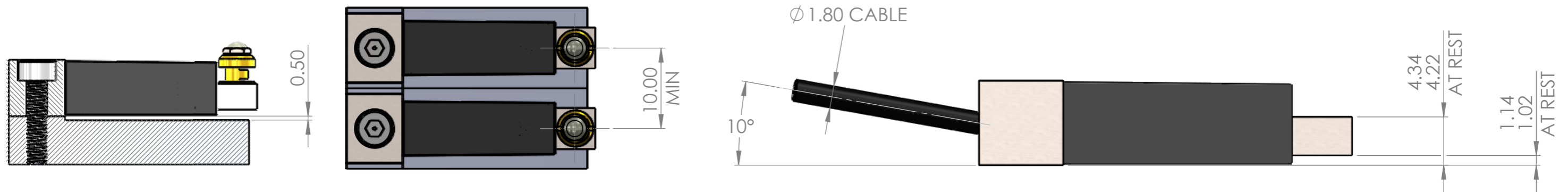

VIEW 'A'

VIEW 'B'

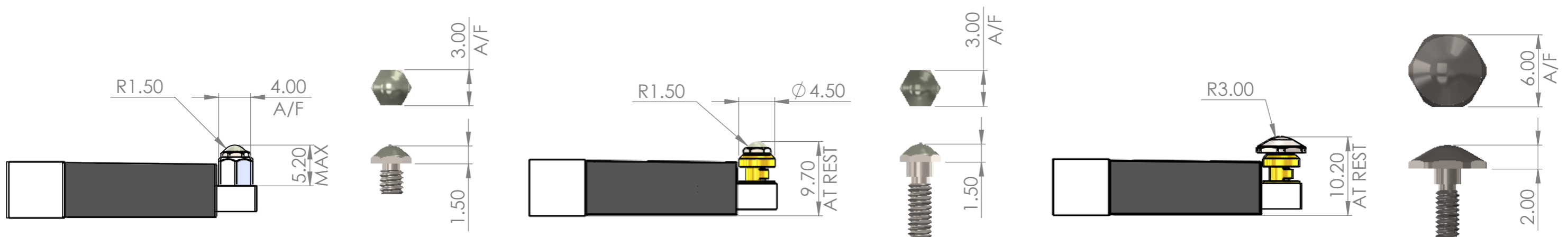

TYPE 'Y' FIXED TIP ASSY VERSION

FIXED TIP P/N 210116

TYPE 'Z' - ADJUSTABLE TIP ASSY VERSION ±0.25mm ADJUSTMENT

ADJUSTABLE TIP P/N 208910

TYPE 'Q' - ADJUSTABLE HIGH LIFT TIP ASSY VERSION ±0.25mm ADJUSTMENT

ADJUSTABLE TIP P/N 209869

 STEYNING WAY • BOGNOR REGIS • SUSSEX • ENGLAND • PO22 9ST	DRAWING NUMBER	TITLE	E.D.C.R.	24093
	540002-084	DUSM/05/S SINGLE LEAF MINI FLEXURE	ISSUE	6
SOLARTRON PURSUES A POLICY OF CONTINUOUS DEVELOPMENT. SPECIFICATIONS IN THIS DOCUMENT MAY THEREFORE BE CHANGED WITHOUT NOTICE. DIMENSIONS ARE NOMINAL AND SPECIFIED IN MILLIMETRES				